

Supervisors in Multi-Voltage Systems

As processors become more complex, ensuring proper operation becomes more involved and more is demanded from supervisory circuits.

- *Multi-voltage supervisors provide power-on reset, proper sequencing, and continuous voltage monitoring.*
- *The lower voltage requirements in today's state-of-the-art processors demands the use of new low-voltage monitors.*
- *Modern supervisors provide additional functions such as watchdog timers, manual reset input, and power fail comparators.*

As higher component density and processor speed demanded lower voltages for the core supply, multi-voltage systems began to appear. The first such systems were dual-voltage designs for the logic and core. Advances in FPGAs, custom ASICs, and other products added a third, and sometimes a fourth, voltage level. Maxim supervisor ICs have kept pace with the development of increasingly complex products, providing monitoring and control for complex, multi-voltage systems.

Multi-voltage supervision

In multi-voltage systems, the simplest way to generate a Power on Reset (POR) signal is to monitor the 3.3V or 5V logic supply. At power-up, when the logic voltage rises above its threshold, the supervisor initiates a reset period to ensure an orderly turn-on of the processor. As long as the processor's supply voltage is within specifications (during normal operation), the supervisor continues to monitor that voltage for transient and brown-out conditions.

But what about the integrity of devices operating at lower levels of core/supply voltage? Those levels are generated from linear or switching power supplies, so how can you assume they are within specification before the reset period has elapsed? By monitoring only a single voltage in a multi-voltage design, the risk can go undetected that improperly powered devices may be loading the bus or responding in an erratic manner, causing software to deviate from its expected procedure. A good foundation for reliable design must therefore include the ability to monitor all voltages.

Available supervisors can monitor two, three, or even four supply voltages, either with factory-programmed thresholds or with a combination of factory and resistor-programmable thresholds. Factory-programmed thresholds are usually available in increments of 50mV to 100mV below

the monitored voltage level, so a supervisor is selected according to its specified tolerance. If, for example, a supervisor family specifies thresholds of 3.3V, 3.08V, 2.93V, and 2.63V, you compose a part number for the device by noting the desired voltage and its corresponding suffix.

Factory-programmed supervisors are single-chip devices that require no external components for threshold settings. The absence of resistor dividers for the thresholds also eliminates a source of power dissipation. Resistor-programmable devices, on the other hand, are suitable for engineers who want to avoid an application-specific device. Once your company qualifies a particular supervisor, you can easily change its threshold by substituting one or two resistors. And for single-supply systems, you can use the same multi-voltage supervisor after disabling its other inputs.

Low-voltage supervision in multi-voltage systems

The movement of logic levels from 5.0V and 3.3V toward 2.5V and 1.8V is creating a need for supervisors that can monitor voltages as low as 0.9V. Such supervisors should operate directly from 1.8V, because the higher voltage levels will not always be available. The smaller difference between active and inactive states also poses a need to maintain valid reset operation down to supply levels of 1.0V and lower. The ability to reject short-duration transients in the supply voltage (good transient immunity) is another feature critical for low-voltage systems. Many data sheets include a graph of transient duration vs. voltage overdrive, which allows the designer to avoid nuisance resets by reviewing noise characteristics inherent in the power supply.

Device operation and features

The currently available families of off-the-shelf supervisor ICs are extremely flexible in meeting system needs. Besides multi-voltage monitoring, they offer features that make designs more robust and less susceptible to transient conditions in the hardware and software. The following considerations are critical in selecting a supervisor.

Reset Period:

Reset Period is a delay interval following the rise of all monitored voltages above their reset thresholds, during which the reset output is held low. A popular value is 140msec minimum. Thus, the reset pin remains active for at least 140msec after all monitored voltages have risen above their thresholds. Reset commands vector the software to a specific code location from which an orderly start-up can be initiated.

Resets also occur in response to a low voltage, manual reset, or watchdog timeout. Reset initializes the code, and thereby prevents the processor from executing code that might have been corrupted by a low voltage or software bug. If processor specifications permit, it may be more suitable to increase or decrease the reset period. Available devices provide reset periods ranging from 1 millisecond to 1.2 seconds.

The reset period also allows the supply voltages, crystal, and phase-locked loop (PLL) to

stabilize. The crystal and PLL have the largest effect on reset period duration. A 20MHz crystal without PLL can use a short timeout, but a 32kHz crystal phase-locked to 20MHz with a PLL requires a longer timeout.

Reset Output:

An active-low push-pull reset output is appropriate for most applications, but other output types are available. For applications in which a supervisor replaces the RC delay associated with a traditional 8051 product, the supervisor has an active-high push-pull output or an active-low open-drain output, or both.

Open-drain outputs are generally more flexible. They allow simple wire-OR connections, and easily form an interface to devices operating at different system voltages. Open-drain outputs allow the Reset output to be pulled low by multiple sources without contention. The penalty for that flexibility is the external pull-up resistor.

Push-pull outputs in single-voltage systems are straightforward, but those in multi-voltage systems require more care. Consider, for example, a dual supervisor used to monitor 3.3V and 5.0V supplies. For the two internal voltage monitors it has one push-pull reset output, which can swing between ground and the 3.3V rail or (in another version) between ground and the 5V rail. In that case you choose the version whose voltage swing is compatible with the processor's reset input. Or, the dual supervisor may have two outputs—one associated with the 3.3V monitor, and one with the 5V monitor. You can choose a version in which each output swings to the corresponding monitored rail, or both swing to the same rail.

Negative-going Transients Immunity:

Noisy digital environments can impose voltage transients on a supply voltage regardless of whether it is generated by a linear regulator or a switching converter. The key goal is to avoid nuisance resets during normal operation while maintaining continuous monitoring of the supply voltage. A graph (available in the data sheet for a typical device) provides guidance on what combination of transient overdrive magnitude and duration will cause a device reset (Figure 1).

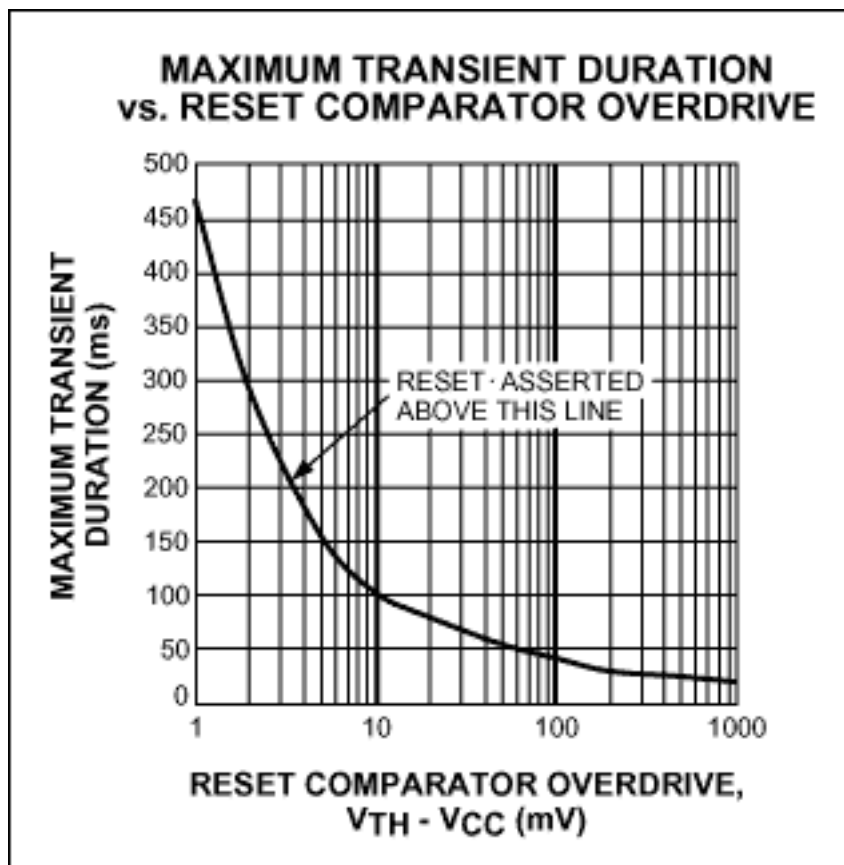

Figure 1. Typical Transient Duration vs. overdrive (graph) for the MAX6381.

As you can see, a 50µsec, 50mV transient will not reset the device; resets occur only for transients of longer duration or greater magnitude. Thus, the graph provides a means for avoiding the dreaded nuisance resets. Note that supervisors with a higher level of transient rejection may also permit the use of a lower-cost power supply requiring less filtering (assuming the processor can tolerate the resulting supply-voltage variation).

Watchdog Timer:

Watchdog timers check for proper software execution. If the software sticks in a loop caused by a bug or hardware failure, the watchdog timer resets the processor and allows it to reinitialize itself. To avoid a reset, the software must generate an edge transition at the watchdog input before the end of each timer period. An edge transition (rather than an active low or high input) removes the possibility of disabling the watchdog due to a locked processor output. You must place timer resets (edge transitions) in the software at locations that ensure a reset of the watchdog before the timeout period elapses.

The art in implementing a watchdog timer is to place the timer resets so they preclude the possibility of a stuck loop. A handy tip is to force a low-to-high transition in one routine and a high-to-low transition in the next routine in the sequence. Then, a reset will occur if the software is stuck in one of the routines. Placing a low-high-low pulse in a single subroutine does not produce a reset, so the software could remain locked.

To accommodate processors with extended power-up and stabilization requirements, some

supervisors provide longer initial watchdog periods. A longer period allows the processor time to initialize and configure itself before implementing the subsequent shorter and more rigorous watchdog intervals.

Manual Reset:

Manual Reset makes available to users and functional test devices an easily accessible means of resetting the processor. Several supervisor products provide an active-low input with internal pull-up resistor, which eliminates the need for an external resistor and also allows for a simple switch interface. Another specification associated with the Manual Reset input is glitch rejection. To avoid an unintentional or nuisance reset, the input should reject short-duration glitches. Such glitch-rejection circuitry not only prevents unintentional resets, but also eliminates the need for external switch-debouncing circuitry.

Manual resets typically trigger a reset period. To reduce test time, however, the reset period should be short. MAX6390 ICs address this concern with periods about one-eighth that of a standard reset period (for a MAX6390D4, the Manual Reset pulse is 140msec minimum and the reset period is 1.12sec).

In addition to level-sensitive manual-reset inputs, some applications may require edge-sensitive inputs, which ensure that the processor is reset for a fixed period rather than a period that depends on how long the manual-reset input is held low. That capability is handy for reducing product-assembly and test time.

Overvoltage and Negative-Voltage Monitoring:

For medical or safety-related equipment that performs self-testing, supervisors are available that enable the detection of both over-voltage and under-voltage conditions. These devices have resistor-programmable inputs that force a reset when the monitored voltage exceeds a threshold. Like the under-voltage condition, excessive voltage can cause unexpected results in firmware as well as hardware. Forcing the processor into reset mitigates a potentially unsafe condition.

Analog-output failures can occur in a number of ways, but a simple negative voltage monitor can confirm that the expected supply voltages are present and within specification. Analog modules with -5V or -15V rails, for instance, often produce analog outputs for which there is no supply-voltage feedback to verify their validity. Fortunately, an over-voltage monitor can also monitor a negative voltage. As for the over-voltage case, the supply voltage is sensed by an external resistor divider between that voltage and Vcc (Figure 2).

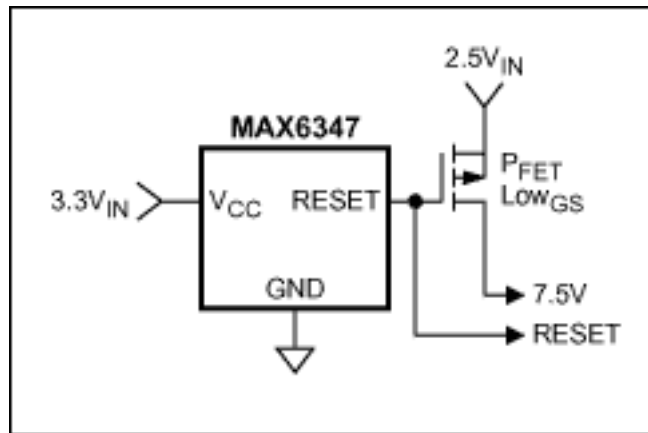

Figure 2. Negative voltage monitor using the MAX6347.

Power sequencing:

To prevent latch-up and to maximize reliability during power-up, a multi-voltage system often includes a requirement to sequence or track the I/O to Vcore or Vcore to I/O voltages. Tracking generally means the I/O and core voltages must rise together, and (usually) the core voltage must not exceed the I/O voltage by more than 0.30V. Sequencing generally means that the I/O voltage must rise before the core voltage. The system may also specify a delay period between the rise of the I/O and core voltages.

One type of sequencer for a 2-voltage system (I/O = 3.3V and core = 2.5V) employs a single-voltage supervisor that monitors the 3.3V supply. When that voltage is above its threshold, the supervisor delays and then enhances an external p-channel MOSFET (Figure 3). That approach is cost effective for low-current applications, but for higher currents the cost of a low-Rdson p-FET with low Vgs threshold can be high.

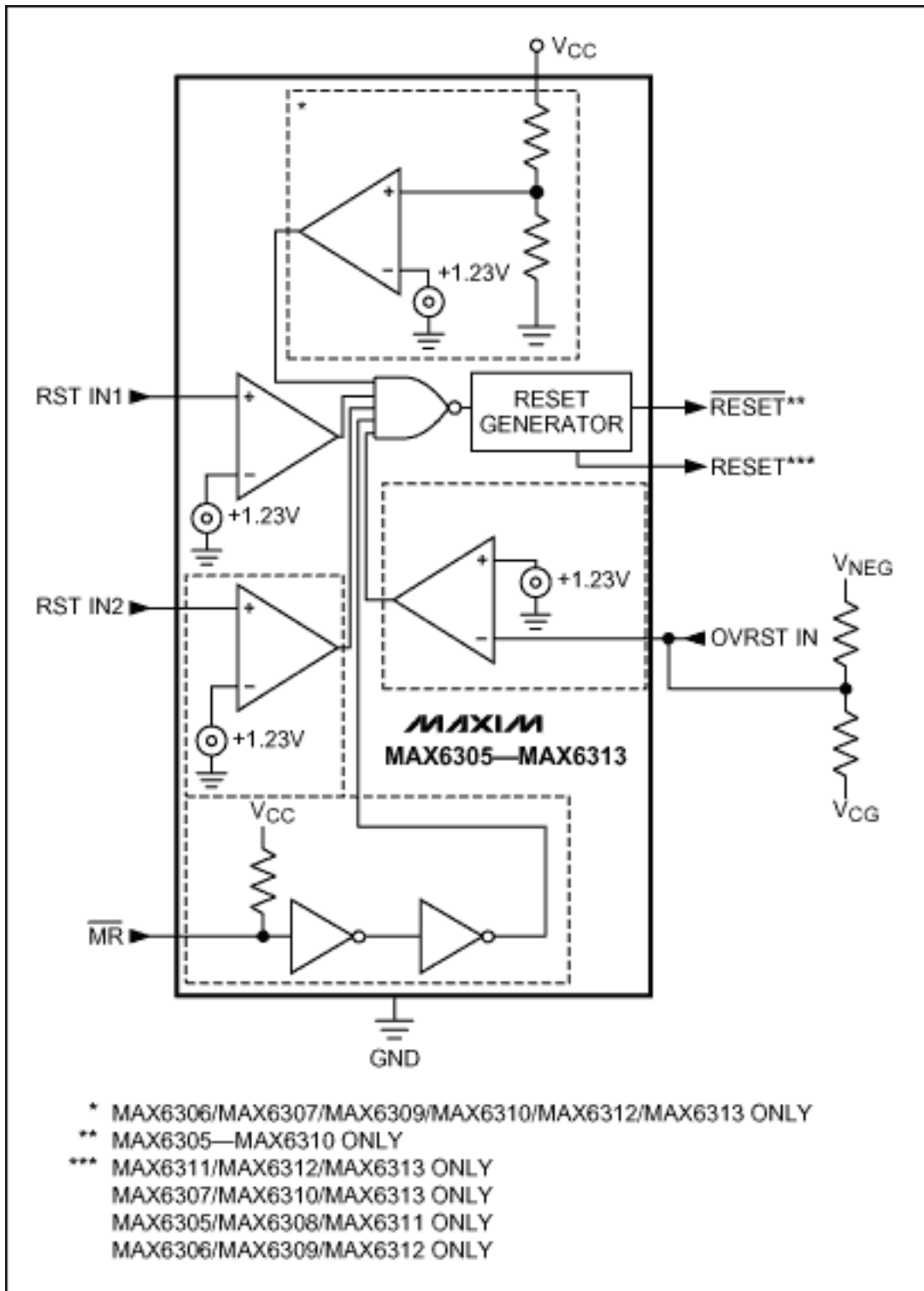

Figure 3. Power sequencer using the MAX6347.

For higher-current applications, a dedicated power sequencer with charge pump may be more effective. As in the preceding example, this circuit monitors a supply voltage and activates an external FET to bring up the second supply. The IC device, however, allows use of an n-channel FET that costs less than the p-channel device. The internal charge pump provides a V_{gs} of 5.0V, which fully enhances the n-FET powering the second supply. Not only does the n-FET cost less; its R_{dson} is notably lower.

As examples, the MAX6819 and MAX6820 are SOT-23 power sequencers that require no external charge-pump capacitors. The MAX6819 has a fixed 200msec delay, and the MAX6820 has a variable delay. An external capacitor sets the delay according to the relationship

$$t_{\text{DELAY}}(\text{sec}) = 2.484 \times 10^{-6} (C_{\text{set}}).$$

These ICs also enable straightforward sequencing in applications with more than two supply voltages. To sequence all supplies, you simply add one sequencer for each additional supply voltage (Figure 4).

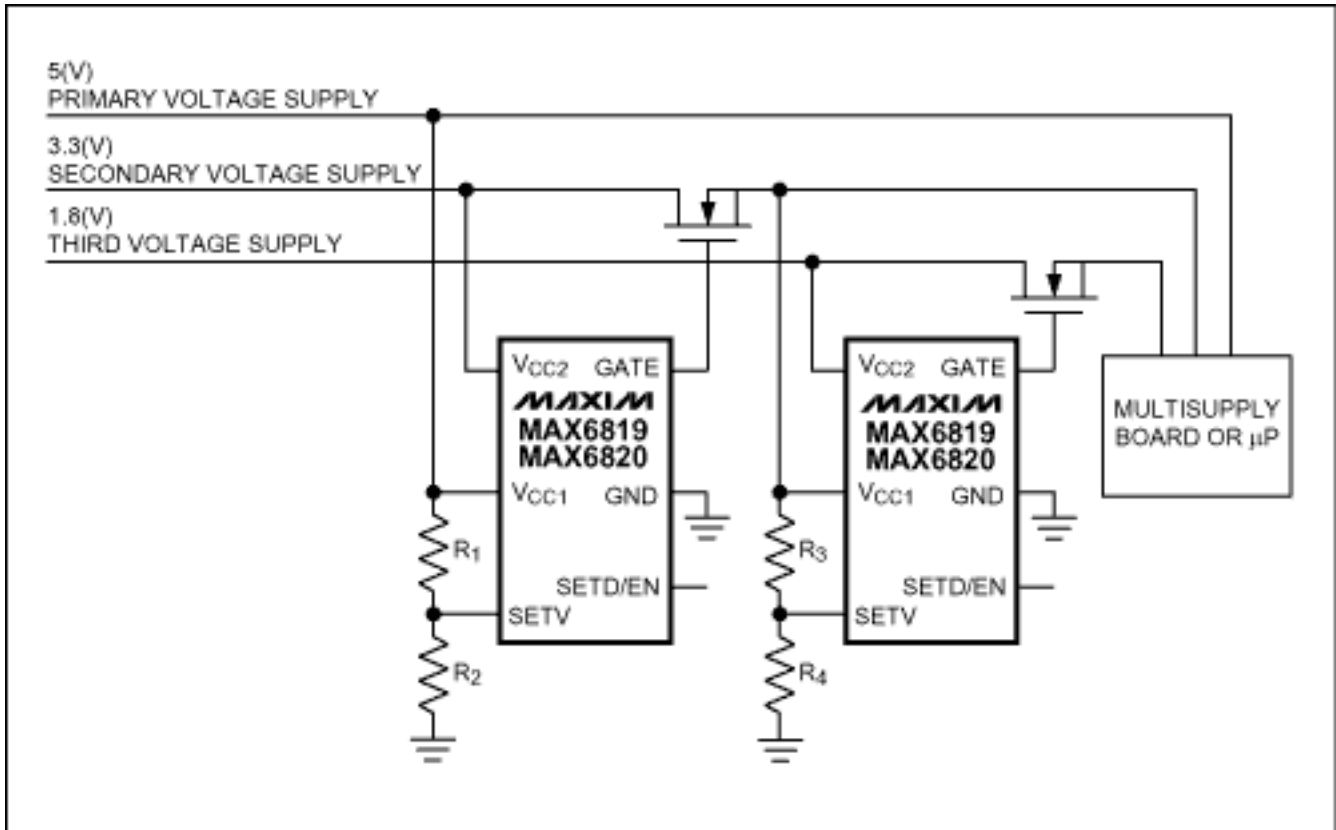

Figure 4. Sequencing an additional supply.

Power-fail comparator:

If your system must provide an early warning of power loss or low battery voltage, you can choose a supervisor that includes a logic-level reset circuit and power-fail comparator. For ICs of the MAX6342 family, for example, the reset threshold is factory trimmed. (An external?) YES resistor divider sets the threshold for power loss or low-battery detection. Because the threshold is at 1.25V, you can monitor voltages above and below Vcc, with the minimum threshold at 1.25V. For additional supply voltages, choose a device with open-drain outputs, which allows use of a second supervisor to monitor the other core voltages.

Voltage Detection:

The importance of monitoring all supply voltages in a system cannot be overemphasized. It can be performed via feedback, or by a supervisor driving the reset pin of a processor. Feedback

can be in the form of an A/D converter measuring system voltages, or a software routine monitoring device functionality. Either approach assures the engineer of proper power on the board.

Another simple method achieves the same result with voltage detectors. Voltage detection can be more informative than supervision, because it indicates which supply voltage has a problem. Supervision usually ORs together all voltages and generates a single reset, whereas a multi-voltage detector usually offers open-drain outputs that can be reviewed individually to determine the source of the problem. Quad-voltage monitors are available with independent open-drain outputs. Such devices can include resistor-programmable thresholds as well as factory-programmed thresholds that accommodate supply voltages of 1.8V, 2.5V, 3.3V, 5.0V, or -5.0V. An internal precision voltage reference and internal voltage dividers make these ICs very compact.

Summary

The combination of multiple supply voltages, shrinking die geometries, and increasingly important product reliability specifications has elevated the need for complete supervision or monitoring of supply voltages. This article has described the products available for that purpose, and the product features critical in designing a reliable system.

More Information

MAX6338: [QuickView](#) -- [Full \(PDF\) Data Sheet](#) -- [Free Samples](#)

MAX6339: [QuickView](#) -- [Full \(PDF\) Data Sheet](#) -- [Free Samples](#)

MAX6391: [QuickView](#) -- [Full \(PDF\) Data Sheet](#) -- [Free Samples](#)

MAX6392: [QuickView](#) -- [Full \(PDF\) Data Sheet](#) -- [Free Samples](#)

MAX6700: [QuickView](#) -- [Full \(PDF\) Data Sheet](#) -- [Free Samples](#)

MAX6709: [QuickView](#) -- [Full \(PDF\) Data Sheet](#) -- [Free Samples](#)

MAX6710: [QuickView](#) -- [Full \(PDF\) Data Sheet](#) -- [Free Samples](#)

MAX6714: [QuickView](#) -- [Full \(PDF\) Data Sheet](#) -- [Free Samples](#)

MAX6819: [QuickView](#) -- [Full \(PDF\) Data Sheet](#) -- [Free Samples](#)

MAX6820: [QuickView](#) -- [Full \(PDF\) Data Sheet](#) -- [Free Samples](#)